

NAM:TECH
Institute of Manufacturing Innovation

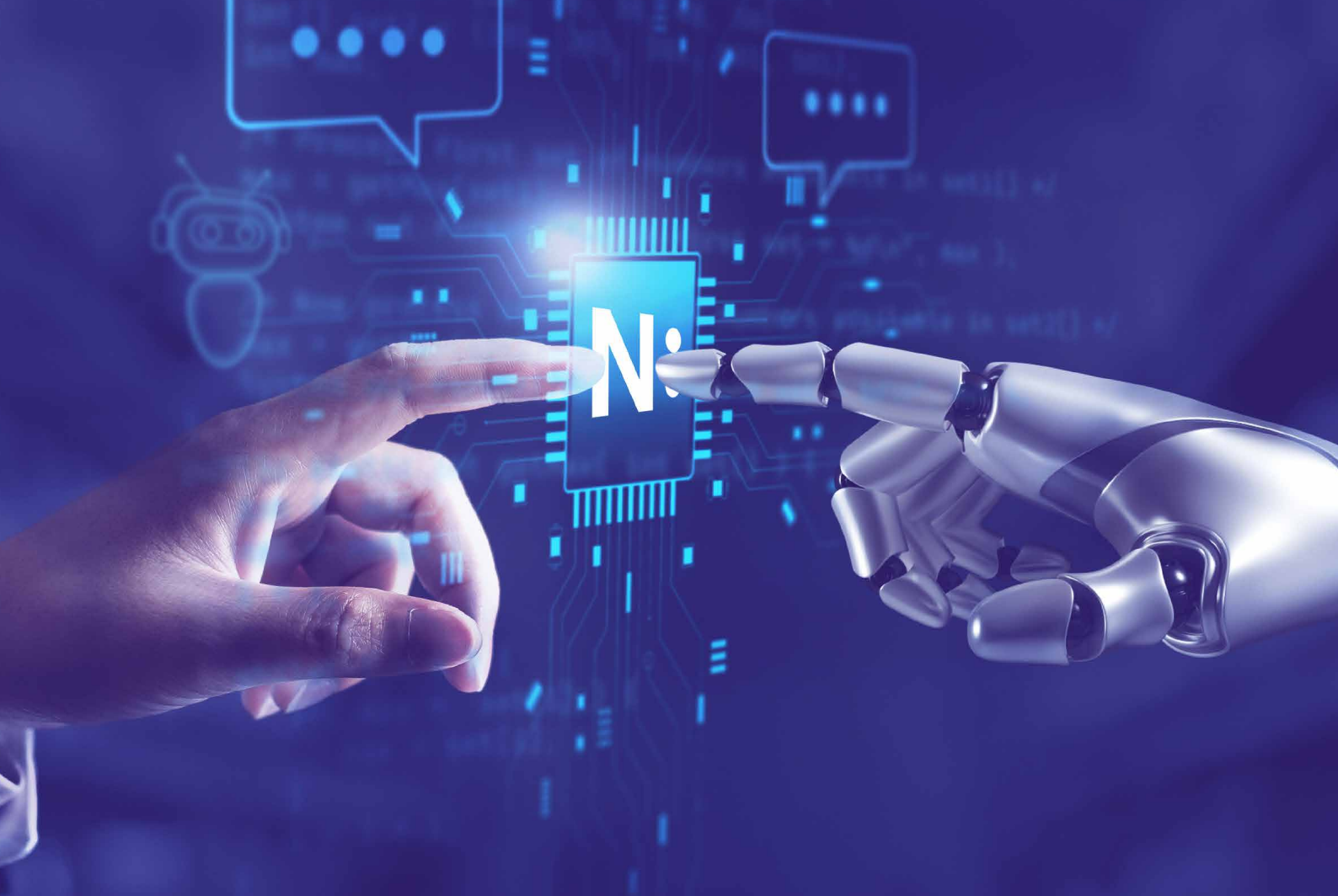

PLACEMENT BROCHURE

iPTP 2025-26



Smart Manufacturing is Powering India's Next Industrial Leap



The manufacturing sector currently contributes **~17%** to India's GDP and is expected to increase to **~25% by 2030** under the Make in India initiative.



~6.8 crore people were employed in the manufacturing sector in India in 2022-23.



India is expected to generate **~3.5 crore (35 million)** new manufacturing jobs in the coming years through industrial expansion and policy initiatives.

Source:

1. <https://www.pib.gov.in/PressReleasePage.aspx?PRID=1962137®=3&lang=2=>

2. <https://www.dataforindia.com/measuring-manufacturing>

3. <https://www.pib.gov.in/PressReleasePage.aspx?PRID=2168711>

India's smart manufacturing future demands a new generation of industry-ready professionals

NAMTECH was established to develop the next generation of manufacturing professionals in areas such as Smart Manufacturing, Sustainability, Semiconductors, Robotics, Automotive, and Data Analytics & AI, supporting India's vision of Viksit Bharat 2047.

Launched in 2024, the flagship International Professional Technologist Programme (iPTP) brings experiential learning, automation, robotics, and smart manufacturing exposure to ITI and diploma students across India. The programme aims to upskill and educate students in the latest technologies, making them industry-ready from day one. In just two years, students have achieved what is uncommon at the ITI level, securing two patents for innovations for a solar-powered seed sowing robot and a portable microphone stand. This reflects a shift from skill-based learning to innovation-led capability.

iPTP Graduates have progressed to leading organisations including L&T Heavy Engineering, Micron, Electrotherm, Pima, and SLTL, with packages reaching up to ₹5.91 LPA and an average of ₹3 LPA.



About NAMTECH

NAMTECH is India's First Institution Driving Manufacturing Innovation.

NAMTECH is committed to meet the demand for Industry 4.0 & Industry 5.0 ready professionals by developing talent that is both technically competent, and conscious towards the environmental & social impact of innovation. The Ministry of Education, on the advice of UGC, has issued a Letter of Intent (LOI) to NAMTECH for consideration as a deemed-to-be -university under the distinct category. NAMTECH is structured around five MET Innovation Schools - Manufacturing Technologies; Manufacturing Design & AI; Robotics; Sustainability; and Technical Education - supported by two MET Innovation Centres (The Centre of Advanced Computing & AI and the Centre of Management Studies) and a Centre of Excellence in Automotive Engineering. Each school & centre offers a full-time Master's programme.

The School of Technical Education at NAMTECH, established in partnership with ITE Singapore, supports technician education and capacity-building within India's ITI ecosystem. The school offers three International Professional Technologists Programme (iPTP) in the areas of Automation, Industrial Robotics, and Semiconductor Manufacturing, as well as supports ITIs in Mehsana, Gujarat, through a uniquely designed hub & spoke model.



artistic image



NAMTECH is shaping a model education ecosystem that integrates advanced learning, applied research, and industry collaboration, with a strong emphasis on innovation, inclusivity, and regional relevance.

The initiative aims to elevate higher and technical education beyond skill development towards the creation of knowledge leaders, innovators, and entrepreneurial talent who can drive long-term industrial and societal transformation.

The model comprises four key components:

100% Experiential Programmes

Immersive, practice-led academic programmes designed to integrate classroom learning with real-world industrial challenges, live projects, and advanced laboratory exposure.

Best-in-Class Campus

A purpose-built, integrated education and innovation campus envisioned as a living laboratory for advanced manufacturing, digital technologies, and sustainability-led solutions.

Groundbreaking Industry & Academic Collaborations

Strategic partnerships with leading global universities and industry players to co-create curricula, enable faculty exchange, and develop translational research & innovation pathways.

Outreach & ITI Upgradation

Structured engagement with regional ecosystems and the ITI network to strengthen foundational technical education, enable pathways into advanced learning, and broaden access to future-ready manufacturing and engineering capabilities.

Message from
Director General



**Dr. Ibrahim Hafeezur
Rehman**

Director General & CEO,
Dean Academic Advancement; R&D
Consultancy
Director, School of Sustainability

Hello,

At NAMTECH, we are committed to shaping the future of Manufacturing Engineering Technology (MET) by creating pathways for skilled talent to evolve into high-impact professionals.

As part of our larger vision to train 3 million learners in Industry 4.0 and 5.0 technologies, the iPTP plays a critical role in bridging the gap between foundational skills and advanced industrial expertise.

Tomorrow's leaders in manufacturing will not only operate technology - they will understand, adapt, and continuously evolve with it. They must be equipped with strong technical foundations, practical problem-solving abilities, and the agility to thrive in dynamic industrial environments.

At NAMTECH, through the International Professional Technologist Program (iPTP) we are focused on building a new generation of industry-ready technologists. This programme is designed specifically for ITI and diploma graduates, enabling them to transition into advanced manufacturing roles by developing deep capabilities in automation, robotics, and Industry 4.0 technologies.

The iPTP goes beyond conventional training - it combines hands-on learning, industry-aligned curriculum, and real-world application to ensure learners are prepared to contribute from day one.



School of Technical Education

The School of Technical Education at NAMTECH is dedicated to transforming India's technician workforce into Industry 4.0 & 5.0 ready technologist. The school focuses on building advanced technical and digital skills, along with systems thinking and ethical responsibility, enabling learners to innovate, adapt, and contribute effectively in a rapidly evolving industrial ecosystem.

Through its flagship International Professional Technologist Program (iPTP) and ITI Outreach initiatives, the school provides experiential learning in automation, industrial robotics, and semiconductor to ITI and diploma students across India. Its mission is to democratize access to future-ready technical skills and nurture professionals who combine technical craftsmanship with conscious innovation.

The school also leads NAMTECH's nationwide "Sharing Technology" initiative, delivering world-class technical training through outreach programs, skill hubs, and the Moving Campus initiative, ensuring that high-quality technical education reaches learners who traditionally lack access.

In collaboration with ITE Education Services (ITEES), Singapore, a globally recognized leader in technical education, all programs follow international standards of hands-on learning, modern pedagogy, and global certification.

Message from

Programme Leader



Mr. Sandeep
Achantani

Director,
School of Technical Education

Hello,

At the NAMTECH School for Technical Education, we believe that India's industrial progress will be defined by the quality of its technicians - the hands and minds that build, automate, and sustain our economy. Our mission is to nurture technologists with conscience – individuals who combine precision with purpose, skill with awareness, and innovation with integrity.

Our programmes, developed in partnership with ITE Education Services Singapore, leaders in manufacturing industry and technology experts, are rooted in experiential learning and global best practices. Whether through our residential training at Gandhinagar or through our outreach programmes that reach ITIs and rural communities, we bring world-class technical education to learners where they are.

Having successfully demonstrated the impact of our hub-and-spoke model in Mehsana, we now aim to scale this innovation through partnerships with MSDE and State Skill Missions – impacting 500 ITIs across India in the next 10 years.

The NAMTECH School for Technical Education stands committed to building an inclusive, skilled, and future-ready workforce that drives India's journey toward Vikasit Bharat @ 2047.

International Professional Technologist Program (iPTP)

The International Professional Technologist Program (iPTP) program offered by NAMTECH School of Technical Education, is a one year full-time, residential program aimed to prepare highly skilled world-class technologists in Automation, Industrial Robotics and Semiconductor Manufacturing.

The programs include 9 months of classroom teaching and 3 months of on-the-job-training. Students who have completed their ITI and diploma are eligible to apply in this course.

The curriculum of iPTP is designed in collaboration with ITE Education Services (ITEES), Singapore, and prominent industry experts of Industry 4.0. iPTP will equip and enable learners to pursue global job opportunities.

Programs Offered

The School for Technical Education offers three specialized iPTP programs, designed to prepare students for advanced manufacturing and emerging technology sectors:

iPTP in Automation

Focuses on modern industrial automation systems and smart manufacturing technologies through project-based learning, competition based learning & competency based learning.

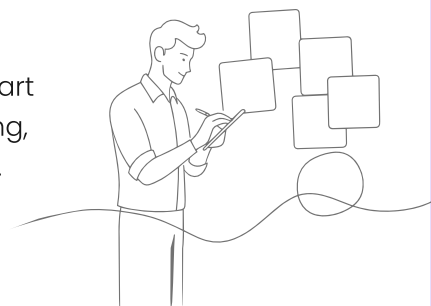

Curriculum

Trimester 1:

- CAD and Mechanical Applications
- Pneumatics and Automation
- Communication and Life Skills – I
- STEM Essentials – I

Trimester 3:

- Cyber Physical Systems
- Robotics Systems
- Communication and Life Skills – III
- STEM Essentials – II
- Capstone Project

Trimester 2:

- Electrical and Electronics Applications
- Hydraulics
- PLC and Motor Control
- Communication and Life Skills – II

Trimester 4:

- On-the-Job Training (OJT)

iPTP in Industrial Robotics

Develops expertise in robotics, automation systems, and real-world industrial problem-solving.

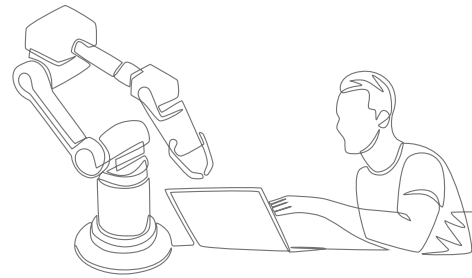

Curriculum

Trimester 1:

- Robot Design & CAD Modelling
- Electrical Components and Panel Wiring
- Communication and Life Skills I
- STEM Essential I

Trimester 3:

- Industrial Robot Integration & Digital Twins
- Mobile Robotics
- Communication and Life Skills III
- STEM Essential II
- Capstone Project

Trimester 2:

- Industrial Robot Programming with Sensor Integration
- PLC and Motor Control
- Industrial Hydraulics and Pneumatics
- Communication and Life Skills II

Trimester 4:

- On-the-Job Training (OJT)

iPTP in Semiconductor Manufacturing

Provides specialized training in semiconductor processes, advanced equipment handling, cleanroom protocols, and contamination control.

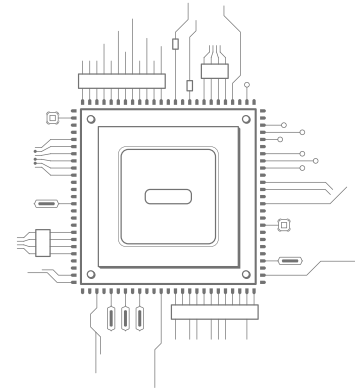

Curriculum

Trimester 1:

- Basic of Electrical and Electronics
- Industrial Automation
- Communication and Life Skills I
- STEM Essential I

Trimester 3:

- Semiconductor Manufacturing Process Fundamentals
- Semiconductor Manufacturing Packing Technology
- Communication and Life Skills III
- STEM Essentials II

Trimester 2:

- Advanced Automation
- Robotics System
- Semiconductor Manufacturing Plant Operation & Safety
- Communication and Life Skills II

Trimester 4:

- On-the-Job Training (OJT)

What sets us APART

01 Global Academic Collaborations



ITEES is a principal provider of career and technical education and a key developer of national occupational skills certification and standards to enhance Singapore's workforce competitiveness.

Established in 2003 with the objective of sharing TVET experience with the international community. Supports more than 30 countries in developing TVET capabilities.

Brings international expertise in the technical training space. NAMTECH is the first industry driven academic partnership done by ITEES in India.

NAMTECH Partners with the best of industries

Our Learning Pedagogy

We are committed to preparing learners for the demands of rapidly changing technology driven competencies of Manufacturing, Engineering and Technology (MET) landscapes, equipping them with the skills and mindsets necessary to innovate. Our pedagogical approach is designed to foster an environment of active learning, critical thinking, and real-world application.

Competency-Based Learning



We focus on mastering skills, not just completing courses. Learners progress through personalized pathways, acquiring technical, professional, and leadership competencies at their own pace. This ensures deep understanding, measurable skill development, and real-world readiness.

Project-Based Learning



Every learner solves real-world problems through hands-on projects co-designed with industry partners. This immersive approach bridges theory with practice and transforms learners into solution-oriented technologists capable of delivering impact from day one.

Competition-Based Learning



To spark innovation and critical thinking, learners engage in challenges and competitions that mirror global industry scenarios. These experiences encourage healthy competition, collaboration, and creativity—pushing learners to raise the bar continuously.

Problem based learning



Our exceptional pedagogy is focused on real-world application of theory and concepts. We encourage our learners to learn concepts, apply them, and validate their understanding in the context of a real-world industry problem.

On-the-Job Training (OJT)



As a part of curriculum students get exposure to work in Industry for three months duration where they apply their acquired competencies in real world work environments. These helps them to develop confidence, industry specific skills and adaptability to make them Industry ready.

State-of-the-art Micro-factories



Our micro-factory learning integrates advanced technologies that mirror real world manufacturing and industrial settings, allowing students a seamless transition into the professional world.

03 Our Achievements

Seeding excellence. Reaping success. Big Win at the Janatics Automation Skill Challenge

Janatics Automation Challenge

SEP 2024



Our students Ankit won Silver, and Suman bagged the Best Project Presentation Award among 2,500 engineers nationwide.

Fanuc India Olympiad

DEC 2024

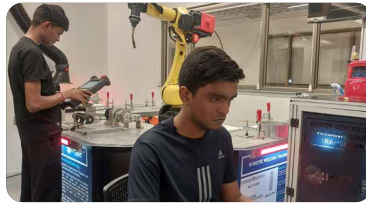

Reached National round during Robotics competition against all engineering institution in India

ABB Robocup

JULY 2025



4 Students selected to participate ABB Robocup Italy.

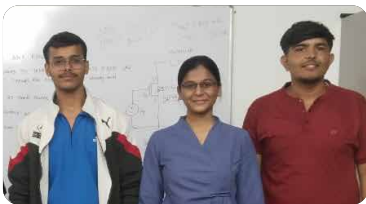

Amalthea- A Tech Fest, IIT Gandhinagar

NOV 2025

Won the first prize during Wire2Win competing against engineers from reputed institutions across India including IITs.

SEP 2024

DEC 2024

JULY 2025

NOV 2025

Solar Powered Seed Sowing Robot

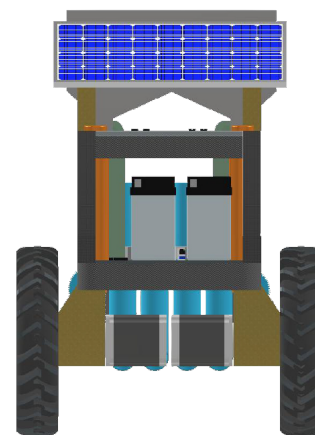
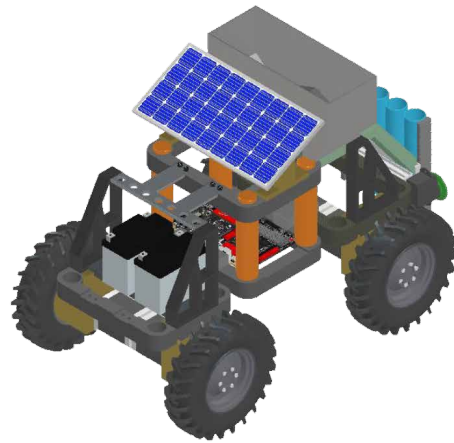
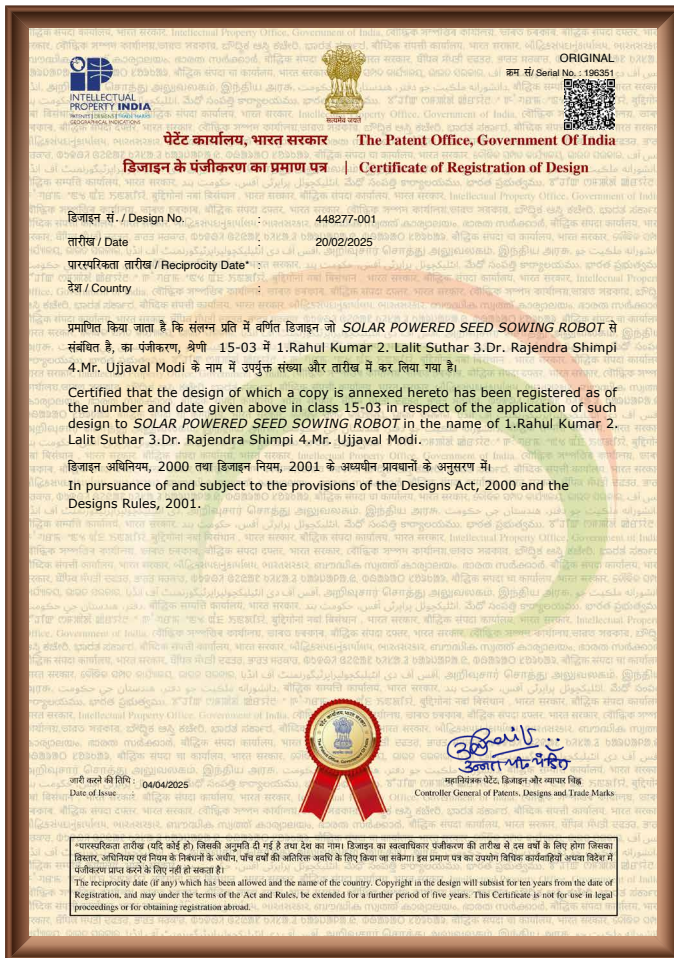

Our iTP students, along with the faculties got patent approval for their innovative design which focuses on a mobile robot that supports sustainable and automated agriculture by using solar power to perform seed sowing tasks with minimal human intervention.

The structure was designed for efficiency, mobility, and adaptability to various terrains - ideal for small and medium-scale farms. Key features of the patented design:

- Compact and lightweight body for smooth field movement
- Integrated solar panel system for clean energy operation
- Seed dispensing mechanism mounted on a mobile frame

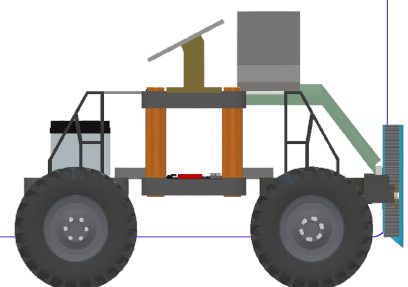

Portable Microphone Stand

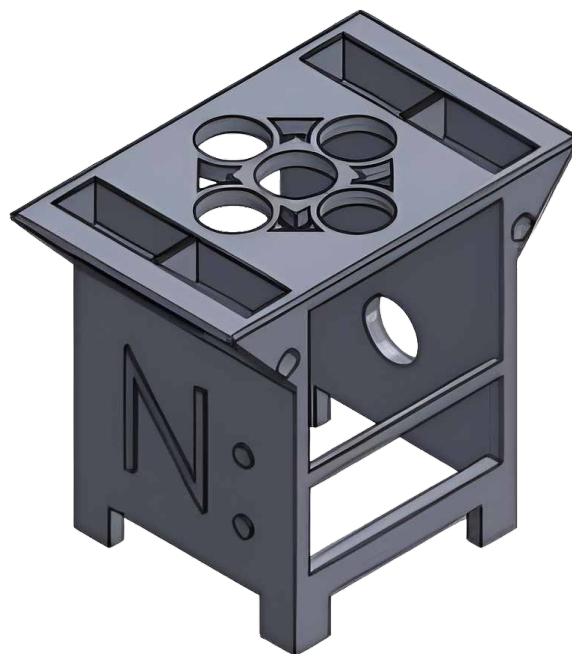
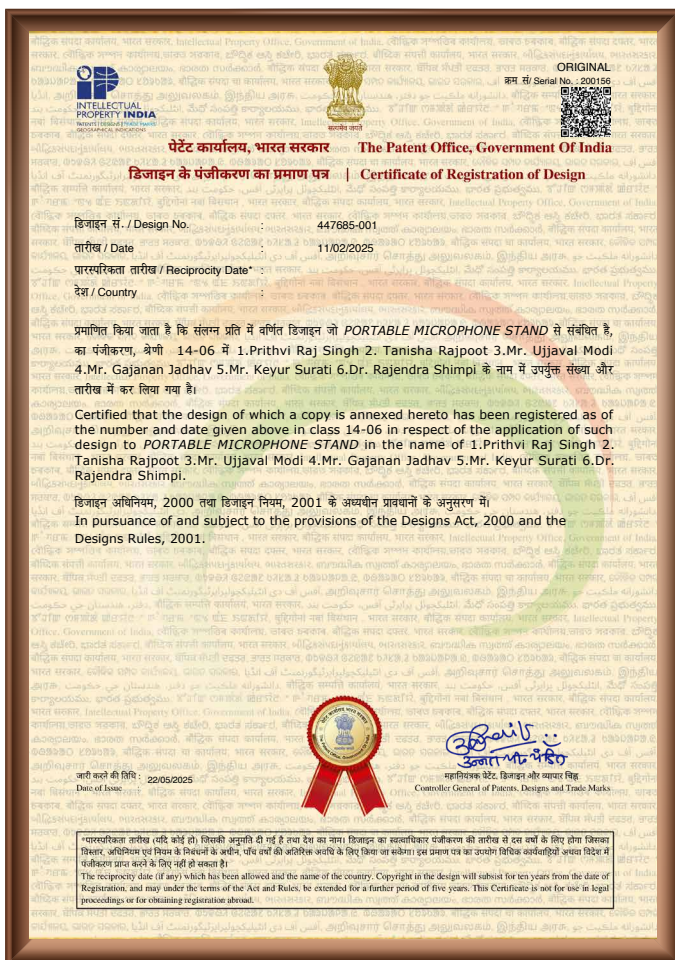

Designed by our iTP students along with faculty members. "Portable Microphone Stand" is engineered as a compact, lightweight, modular support system capable of holding up to four microphones, and designed to provide stable microphone positioning while ensuring ease of transport, quick deployment, and user adaptability.

The design integrates mechanical stability, ergonomic adjustability, and modular construction to meet diverse usage scenarios such as stage performances, studio recording, and field applications.



Dishank Upadhyay

Assistant Professor

Ph.D. (Pursuing) | M.E. in
CAD/CAM & D.E. – Mechatronics



Prashant Parmar

Sr. Lecturer

Ph.D. (Pursuing) |
M.Tech in Mechatronics



Prasad Palkar

Sr. Lecturer

Ph.D. (Pursuing) | M.E. in CAD/CAM



Udayan Trivedi

Sr. Lecturer

Ph.D. (Pursuing) | M.Tech in
(Electronics, Instrumentation & Control)



Keyur Surati

Sr. Lecturer

Ph.D. (Pursuing),
M.E. in Machine Design



Gajanan Jadhav

Sr. Lecturer

Ph.D. (Pursuing) | M.E. in
Mechanical Engineering



Suraj Kamal

Sr. Lecturer

B.Tech in Electronics and
Communication Engineering



Yash Tank

Sr. Lecturer

M.Tech in Manufacturing
Engineering



Ujjaival Modi

Sr. Lecturer

Ph.D. (Pursuing) | M.E. in
Mechanical (CAD/CAM)



Ketu Antani

Sr. Lecturer

M.Sc. – Solid state Electronics



Jay Supat

Lecturer

M.Tech-Turbomachines



Jaya Vadhera

Head- Meta Skills

Bachelor's in Humanities, & Hospitality
Management
Certified: Happiness Practitioner | Life coach

Message from

Director, Corporate Partnerships



Ms. Nandini Dasgupta

Director, Corporate Partnerships

Hello,

It gives me great pleasure to share the continued success of our International Professional Technologist Program (iPTP) – a flagship initiative designed to build a future-ready workforce for advanced manufacturing and Industry 4.0.

Through iPTP, we are enabling young diploma and ITI graduates to transition into high-value roles such as Automation Specialists, Robotics Technicians, and Manufacturing Associates.

The programme combines rigorous, hands-on training in areas like PLC, SCADA, robotics, and digital manufacturing, along with strong industry exposure and professional skills development. We are proud to see our graduates achieving 100% placements in leading organizations, with strong career progression pathways.

As we continue to scale this initiative, we would like to invite you to engage with NAMTECH as a recruitment partner and explore the opportunity to hire from this exceptional talent pool. Our students are trained on industry-aligned curriculum, developed in collaboration with global partners, and are equipped to contribute from day one.

We would be delighted to host you at our campus in Gandhinagar for recruitment interactions or to arrange a virtual engagement at your convenience. We look forward to building a meaningful partnership and supporting your talent needs.

Student Stats – First Batch of April 2024

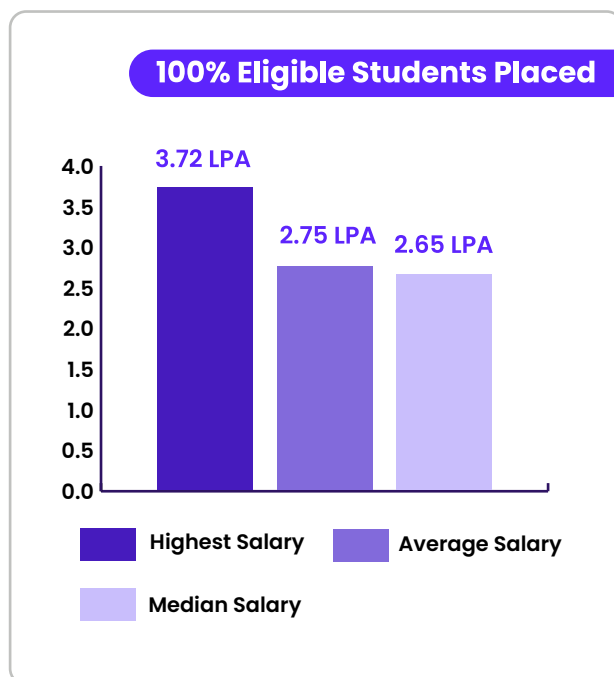
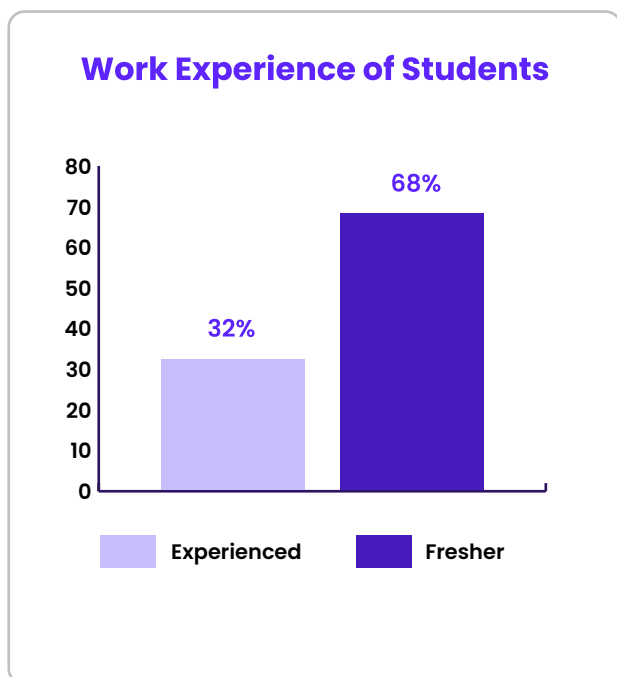
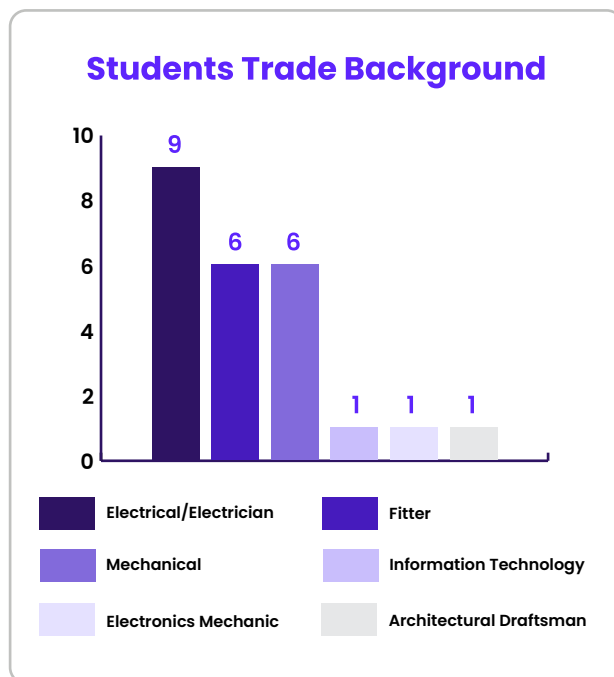
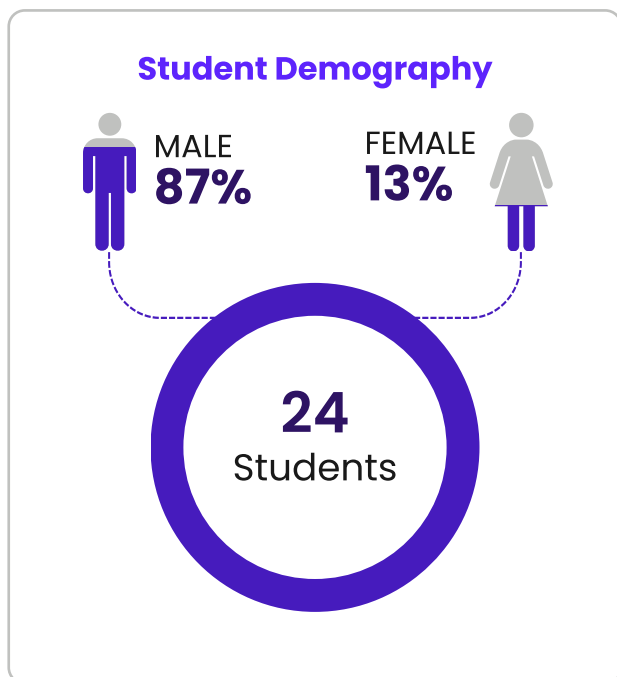

Prominent Recruiters



Student Stats – Second Batch of Sep 2024

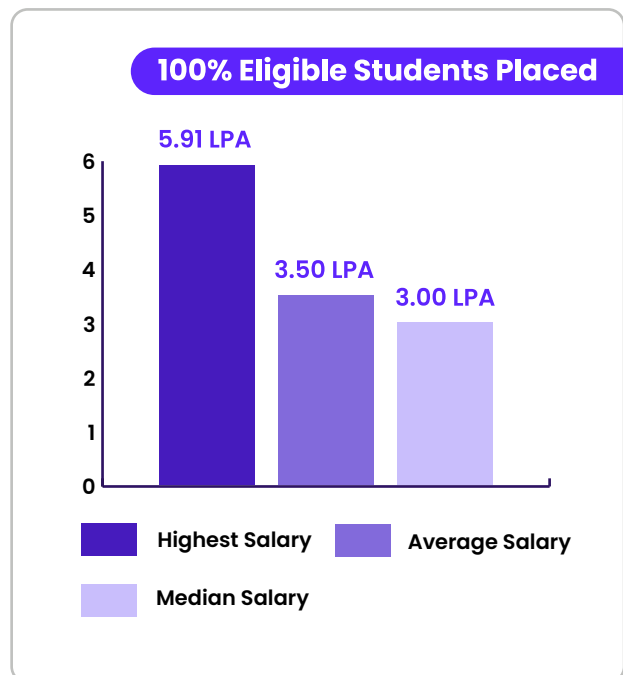
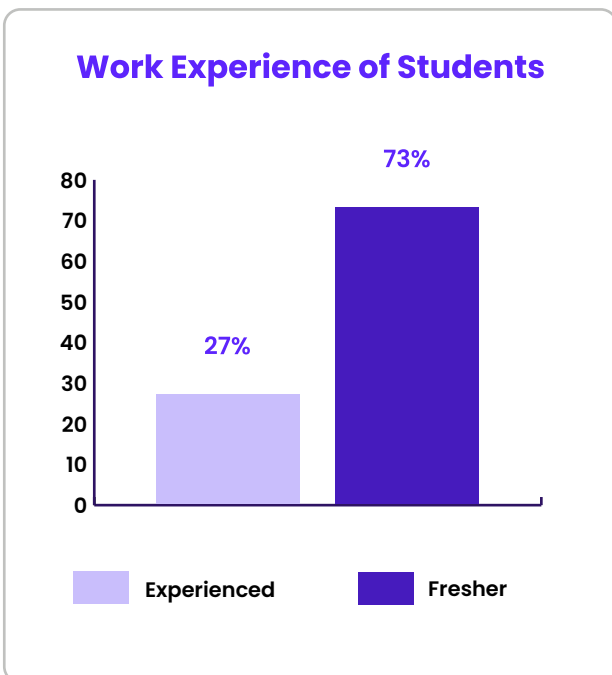
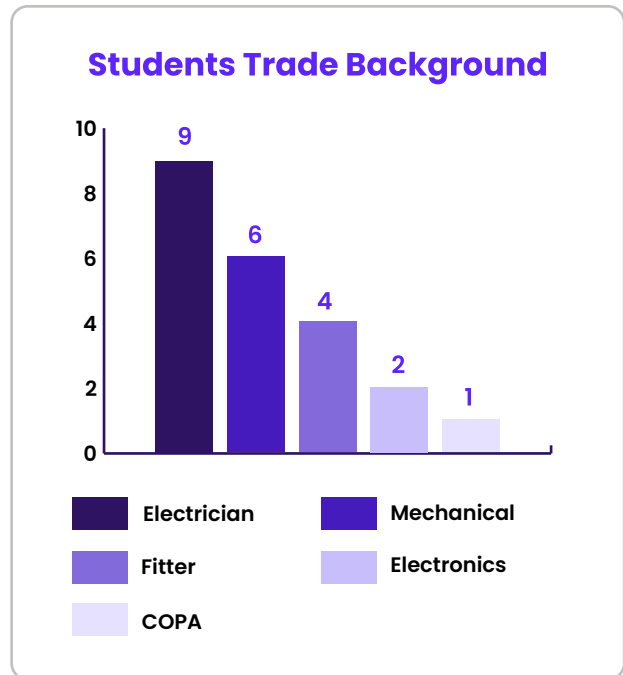
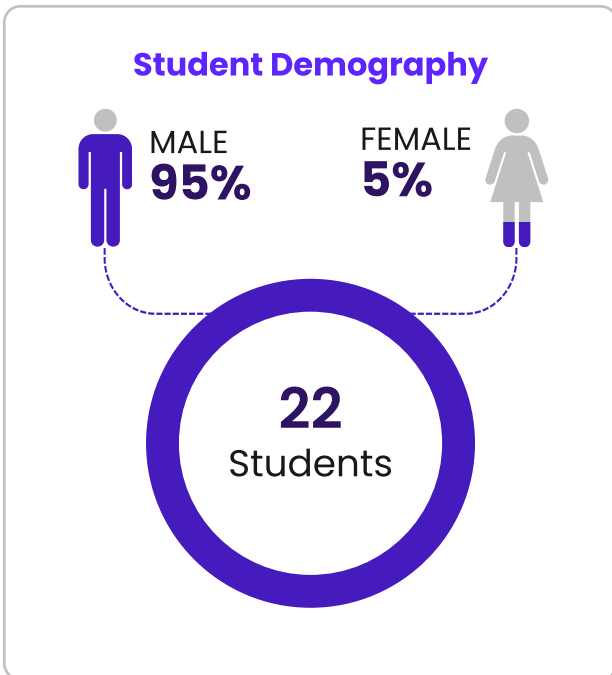

Prominent Recruiters



Student Stats – Batch of 2025–26

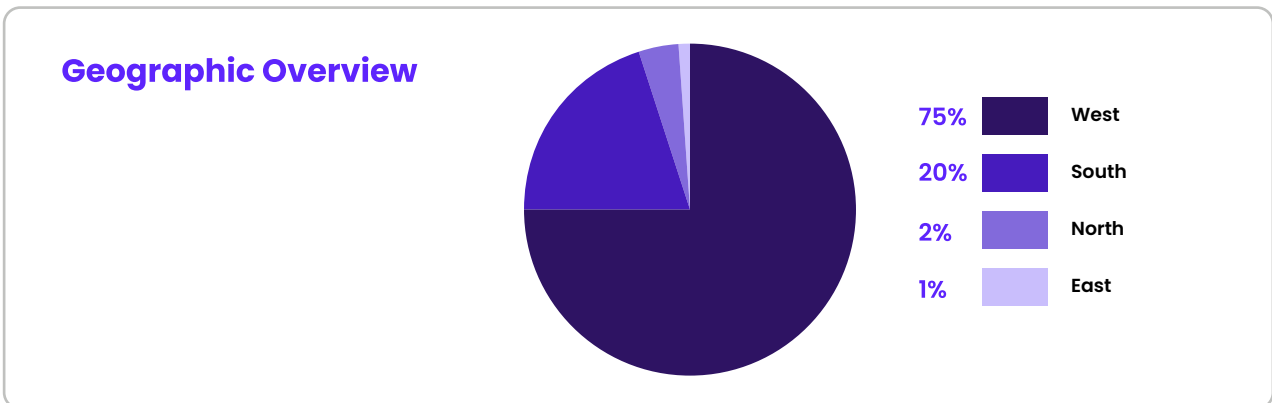
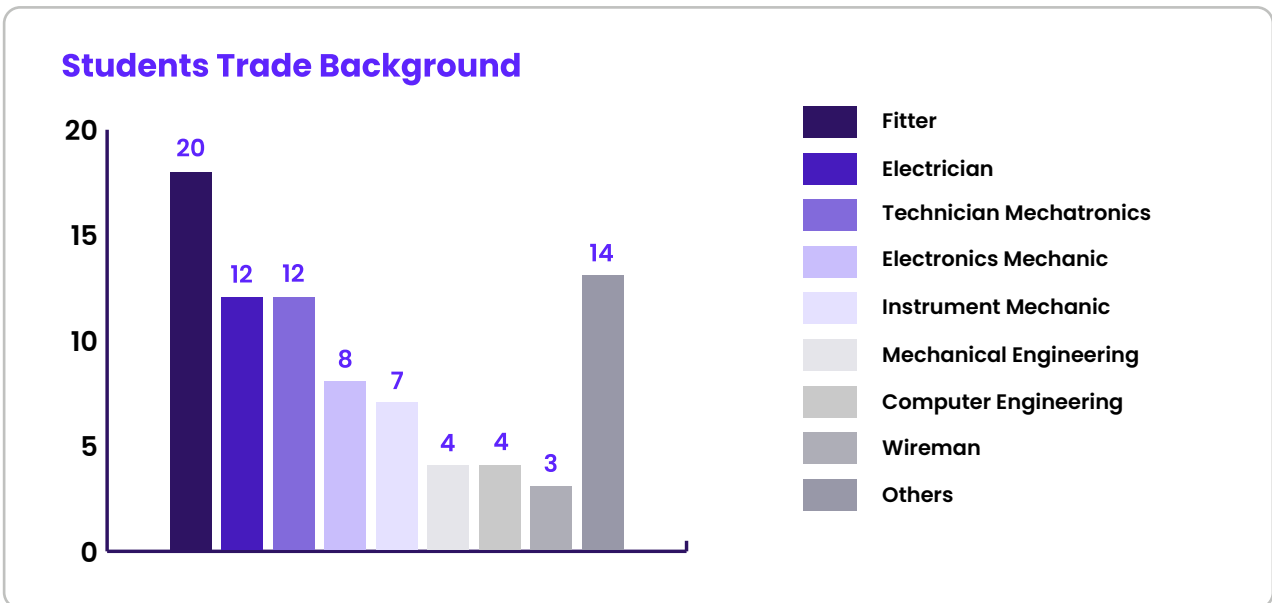
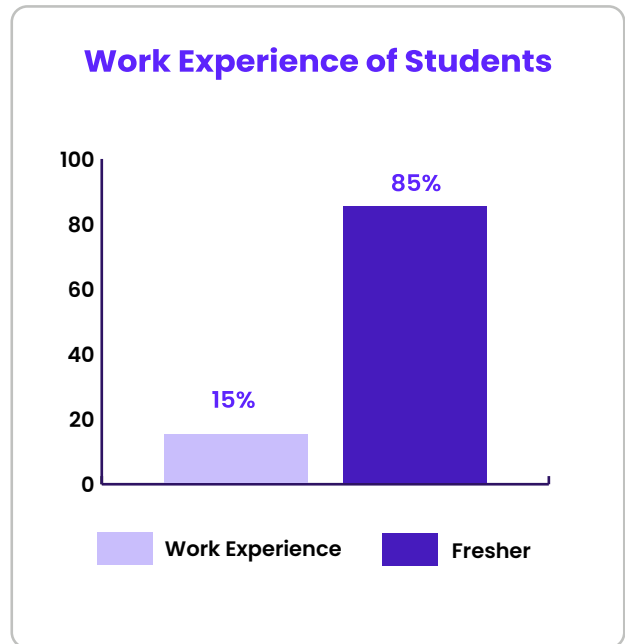
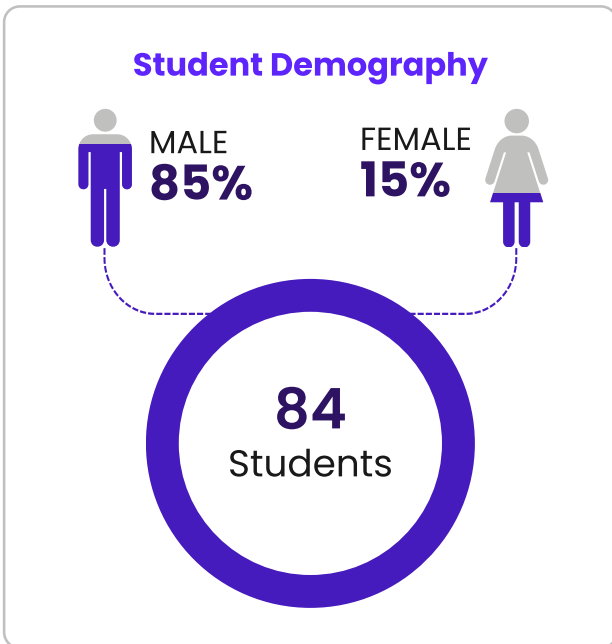

Placement – Roles Offered

NAMTECH has consistently attracted opportunities that align with its focus on developing 'Future Ready Technologist'

Job roles after iPTP program at NAMTECH

- Trainee Technician– Production

- Jr. Officer

- Trainee Technician

- GET - Didactic Sales

- Automation Engineer

- Junior Officer Trainee

- Trainee- Electrician

- GET Plant Maintenance

- GET Operations

- Trainee – Mechanical Technician

- Trainee – Electrical

- Robotics Engineer

- Automation & IIOT Maintenance Engineer

- Trainee Application Engineer

- Manufacturing Associate

- Trainee – Technical

- Technician (Associates) – Maintenance



The industry today demands professionals who combine deep technical expertise with strong managerial acumen, forming a new class of future-ready talent.



In response, NAMTECH is shaping 'Technologist', who are equipped with end-to-end capabilities across manufacturing, engineering, technology, and management, enabling them to contribute meaningfully from day one.



Recruiters are increasingly acknowledging this differentiated value proposition, showing strong confidence in NAMTECH's talent and offering roles that perfectly align with the institute's ethos and the competencies its students are trained to master.

Our Proven Approach is Engineered for 100% Success



Career Coaching & Mentoring

Tailored guidance that connects student individual strengths & career goals with real-world industry opportunities.



Aptitude & Technical Assessments

Insightful evaluations that map student's analytical & reasoning capabilities to drive focused skill enhancement activities and enhance industry readiness.



Mock Interviews

Targeted interview preparation designed to sharpen student's articulation, build executive presence, and promote on-the-spot thinking.



Industry Expert Talks & Alumni Interactions

Engaging talks and masterclasses from industry leaders and alumni that open student's mind to emerging trends, innovation, and growth opportunities.



Capstone Projects

Hands-on projects with industry partners that help students apply their knowledge, solve real challenges, and grow as a strategic thinker.



Feedback & Continuous Improvement

Regular feedback and reflection cycles designed to help students track growth, strengthen skills, and stay ready for the future of work.

Inspiring Student Journeys



Before joining NAMTECH, India's premier institute for smart manufacturing, my knowledge of automation was limited. Now, I've gained expertise in PLC programming, pneumatics, hydraulics, CPS, robotics, and additive manufacturing. NAMTECH's industry-aligned curriculum and world-class infrastructure bridged the gap between theory and real-world applications.

The hands-on training and exposure to Industry 4.0 technologies transformed my learning journey. I'm grateful to NAMTECH for shaping my career and equipping me with future-ready skills.

Shyam Sundar K., Chennai
iPTP – Automation (Batch of April'24)
Diploma in Mechanical Engineering
Placed at MICRON



The iPTP-Automation course at NAMTECH has not only helped me gain knowledge in smart manufacturing but also enabled me to overcome my lack of confidence, especially in communication. With 80% hands-on learning and 20% theory, I gained expertise in CAD, pneumatics, robotics, PLC programming, 3D printing, and mechatronics, along with problem-solving skills.

A proud moment was winning a silver medal in a national competition against 2,000 participants, including B.Tech students. NAMTECH's expert mentorship, industry exposure, and world-class training have shaped my career in automation.

Aniket Jethva, Gujarat
iPTP Automation (Batch of April'24)
ITI – Fitter
Placed at MICRON



NAMTECH is a pioneering institute in industrial automation. Before joining, I had little practical experience. Now, I've mastered PLC programming, pneumatics, hydraulics, CPS, robotics, and additive manufacturing, all aligned with Industry 4.0 standards.

NAMTECH's experiential learning approach, cutting-edge labs, and expert faculty have transformed my technical abilities and confidence. This institute provided me with the tools and guidance to thrive in automation. I'm grateful to NAMTECH for preparing me for a successful career in smart manufacturing.

Shivam Kumar Sah, Jharkhand
iPTP Automation (Batch of April'24)
ITI – Electronics Mechanics
Placed at Micron



After completing my ITI in Architectural Draughtsman, I joined the iPTP-Automation course at NAMTECH. Coming from a non-technical background, I gained hands-on expertise in PLC programming, robotics, additive manufacturing, hydraulics, pneumatics, and Industry 4.0. The practical-focused curriculum, led by global experts, helped me win the Best Project presentation award in JANATICS, a national competition.

As a woman in manufacturing, I believe more women should explore automation careers. NAMTECH's inclusive learning environment empowers us to lead in the evolving world of smart manufacturing. Coming from an ITI background, gaining hands-on experience with NAMTECH's advanced automation tools has been truly commendable.

Suman Agrawal, Maharashtra
iPTP Automation (Batch of April'24)
ITI – Architectural Draughtsman
Placed at AM Construction

Connect with us and engage with
a new generation of industry-ready talent
prepared to drive innovation and impact

Connect with Career Development Services Team



Shailendra Vidhate

Head Placements
NAMTECH

shailendra.vidhate@namtech.ac



Sandeep Parmar

Senior Manager Placements
NAMTECH

sandeep.parmar@namtech.ac



Alok Gosalia

Deputy Manager Placements
NAMTECH

alok.gosalia@namtech.ac

Address:

Research Park, IIT Gandhinagar, Palaj, Gandhinagar, Gujarat - 382055, India

www.namtech.ac | info@namtech.ac | +91-8799299909



Scan here to
enquire